

(No Model.)

2 Sheets—Sheet 1.

W. CHAPLIN.
LATHE.

No. 375,988.

Patented Jan. 3, 1888.

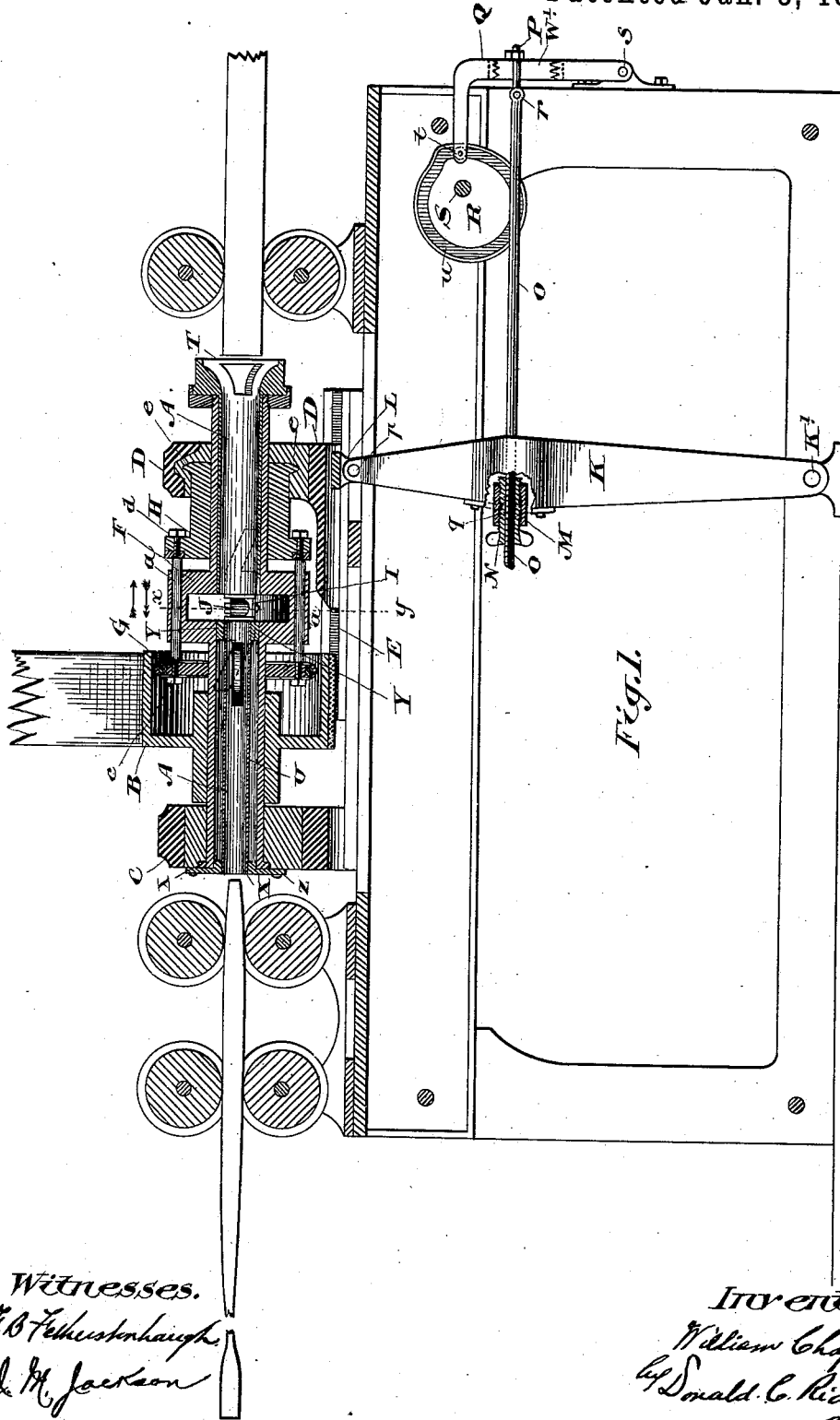

Fig. 1.

Witnesses.

F. B. Feltus
J. M. Jackson

Inventor:

William Chaplin
By Small, C. Rickard & Co
Attys

(No Model.)

2 Sheets—Sheet 2.

W. CHAPLIN.

LATHE.

No. 375,988.

Patented Jan. 3, 1888.

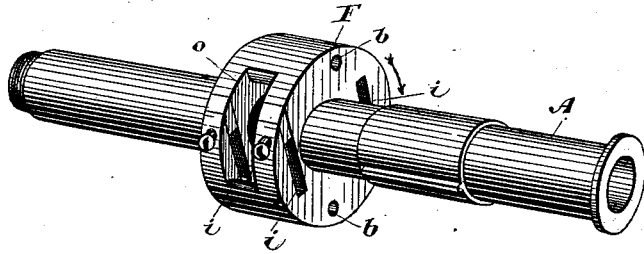

Fig. 2.

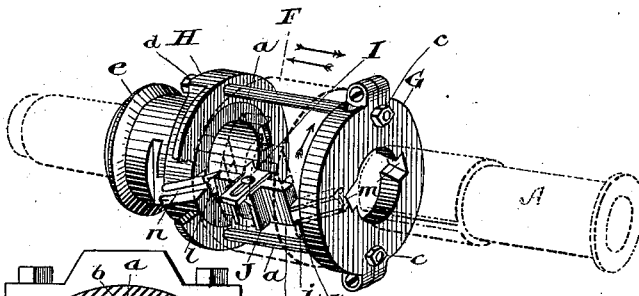

Fig. 3.

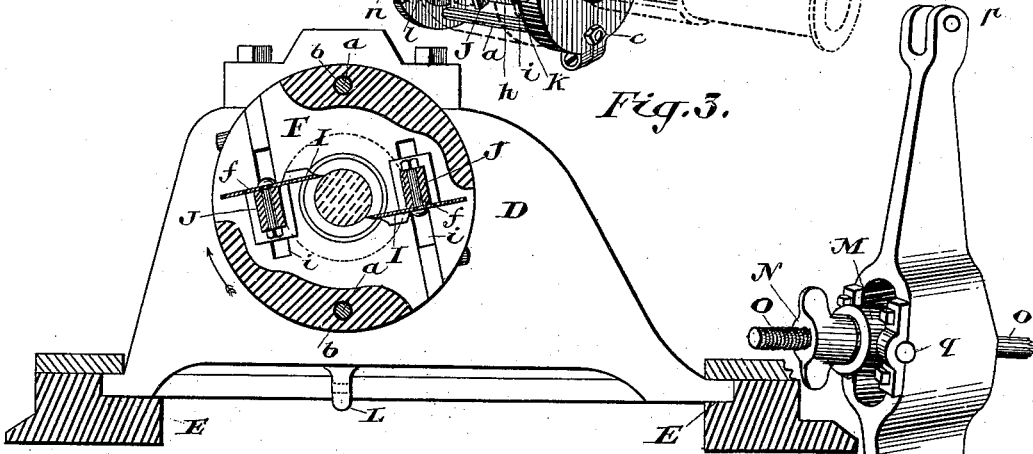

Fig. 4.

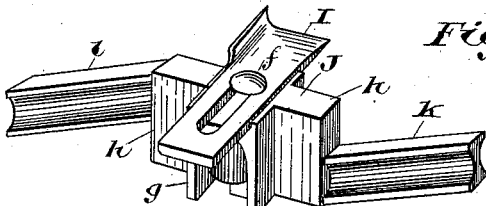

Fig. 5.

Fig. 6.



Fig. 7.

Witnesses.
 F. B. Fetherstonhaugh.
 J. M. Jackson

Inventor:
 Williams Chaplin
 by Donald C. Ridout & Co
 Attys

UNITED STATES PATENT OFFICE.

WILLIAM CHAPLIN, OF ST. CATHARINES, ONTARIO, CANADA.

LATHE.

SPECIFICATION forming part of Letters Patent No. 375,988, dated January 3, 1888.

Application filed July 28, 1887. Serial No. 245,065. (No model.)

To all whom it may concern:

Be it known that I, WILLIAM CHAPLIN, of the city of St. Catharines, in the county of Lincoln, in the Province of Ontario, Canada, manufacturer, have invented certain new and useful Improvements in Lathes, of which the following is a specification.

The object of the invention is to devise a mechanism by which the shaping-knives for tapering handles and other analogous articles may be adjusted and controlled so as to produce a more perfect finish to the handle than the shaping-knives now commonly in use after the cutting-knives have turned off the corners of the stick; and it consists, essentially, in securing the shaping-knives on carriers the arms of which pass through slots cut in a hollow drum forming part of the hollow shaft, through which the handle passes into guides cut in sleeves located on each side of the drum, the sleeves by means of such guides bringing the knife-carriers nearer to or farther from the handles, in order to allow the position of the knives to be regulated by the shape on the pattern-wheel, so as to give the handle the requisite taper, the said sleeves being connected by the sliding standard and the levers and rods connected therewith to the pattern-wheel. A pipe provided with springs steadies the handle while it is being shaped in its course through the hollow shaft, the whole being operated substantially as hereinafter more particularly explained.

Figure 1 is a longitudinal section of the lathe provided with my improvements. Fig. 2 is a detail of the combined shaft and drum. Fig. 3 is a detail of the sleeves for adjusting the knife-carrier, showing one of the knife-carriers in position and one removed to exhibit the carrier-guides. Fig. 4 is a section through xy of Fig. 1. Fig. 5 is a detail of the knife-carrier and knife. Fig. 6 is a detail of lever attached to sliding standard. Fig. 7 is a detail of the steadying-pipe.

In the drawings like letters of reference indicate corresponding parts in the different figures.

A is the main shaft of the lathe, and B the main driving-pulley, keyed on the shaft A. The shaft A is supported at one end by the standard C and at the other by the sliding

standard D, which moves longitudinally on the slide E. The shaft A is hollow and has cast with it the hollow drum F, as shown. On each side of the drum F, on the shaft A, I place the sleeves G and H, which are rigidly held together, but always at the same distance from each other, by the shouldered bolts a . The bolts a pass through holes b in the drum F, and are secured by nuts c and d to the sleeves G and H.

e is a V-shaped annular projection formed on the sleeve H and designed to hold the sleeves G and H securely to the sliding standard D, so that they may move together.

I are the shaping-knives, adjustably secured to the carriers J by the bolts f . The carriers J have shoulders g formed on them at each side of the knife, from which extend the wings h , which move in the slots i , cut in the drum F. The shoulders g , fitted against the sides of the slot i in the drum, keep the carriers J, with their knives I, from moving longitudinally.

k and l are the carrier-arms, formed at an angle to the wings h and extending from opposite sides of the knife-carrier J parallel to each other, as shown in Fig. 5. The carrier-arms k and l of the carrier J are carried in the guides m and n of the sleeves G and H, and as the sleeves G and H are moved in the direction indicated by single-headed arrow the shaping-knives I move at a tangent farther from the center of the hollow shaft, and when in the direction indicated by double-headed arrow the knives I move at a tangent closer to the center of the hollow shaft. (See Figs. 1, 3, and 4.) The shavings created by the action of the knives I are thrown out through the openings o in the drum F.

K is a lever pivoted at K' and connected at p to the lug L of the sliding standard D. On the lever K, I pivot at q a trunnion, M, into which is fitted the hollow-headed thumb screw N, threaded for the screw-rod O.

O is a rod which is screwed into the thumb-screw N at one end and flexibly connected at r to the bolt P, secured in a slot, W', to the bell-crank Q at the other end. By means of this slot W' the bolt P may be made to advance to or recede from the pivot s , and the throw of the sliding standard D may be diminished or increased correspondingly. The bell-

crank Q is pivoted at its lower end at *s*, and has a roller, *t*, pivoted at the end of its upper arm, which roller fits into a groove, *u*, formed in the cam or pattern wheel R. The cam or pattern wheel R is pivoted eccentrically on the counter-shaft S, and is of such a shape as to correspond with the taper desired to be formed on the handle—that is to say, the cam or pattern wheel R is, as its name indicates, so pivoted and shaped as to form the pattern for the different tapers of the handle. As the square stick is fed into the cutting-knives T, the corners are cut off, and the stick is turned round when it reaches the shaping-knives.

At this point the roller *t* is in a position to start the taper of the handle, and as the pattern-wheel R revolves it operates the said roller *t* on the bell-crank Q. The bell-crank Q is connected by the rod O to the lever K, as described, and as the roller *t* follows the groove *u* of the pattern-wheel R the lever K gives the sliding standard D and the sleeves G and H connected to it a reciprocating motion, which brings the shaping-knives I on the carriers J closer to or farther from the center of the handle to produce a taper corresponding with the pattern of the cam or pattern wheel R, the new handle to be shaped being brought up to the shaping-knives I when the roller *t* reaches a certain point in the groove *u* of the pattern-wheel R.

In order to steady the handle while passing the shaping-knives and further accomplish the object of my invention, I place a thin steady-ing-pipe, U, provided with springs *v*, projecting through slots *w* in the pipe U, which is placed in the hollow shaft A at the discharging end and reaching to the edge of the hollow drum F. The pipe U is held in the center of the hollow shaft A by the rings X and Y, and is prevented from revolving with the hollow shaft A by having its elongated end Z screwed to the standard C. (See Figs. 1 and 7.)

It will be seen on reference to Figs. 1, 3, and 4 that the closer the sleeve G is adjusted to the drum F the greater the taper-diameters of handle cut by the shaping-knives I, and the closer the sleeve H is adjusted to the drum F the smaller the taper-diameters of the handle. The sleeves G and H are connected to the standard D, and are adjusted by the thumb-screw N on the screwed end of the rod O fitting into the trunnion M, pivoted on the lever K. The lever K has a throw corresponding to the groove *u* in the pattern-wheel R, which pattern-wheel may be varied according to the pattern desired, which throw may be regulated by the adjustment of the bolt P in the slot W'. It will be seen from this description that the shaping-knives are held firmly to their work and are readily adjustable, so as to give the required taper and finish to the handle.

What I claim as my invention is—

1. In a lathe, the main hollow shaft, a hollow drum cast solid with the main hollow shaft and having slots cut in the drum, car-

riers fitted into said slots, and one or more shaping-knives adjustably attached to said carriers, combined with sleeves on the main shaft engaged with the carriers and adjustable on the main shaft to move the cutting-edges of the knives nearer to or farther from the center of the main shaft, substantially as and for the purpose specified.

2. The main hollow shaft A, the drum F thereon and having slots *i*, the carriers J, having wings *h* and arms *k* and *l*, and the shaping-knives secured on said carriers, in combination with the sleeves G and H, adapted to be adjusted longitudinally on the main shaft, and having guides *m* and *n* formed therein for the reception of the carrier-arms *k* and *l*, respectively, substantially as and for the purpose specified.

3. The main hollow shaft A, the drum F thereon and formed with slots *i*, the carrier J, having wings *h* and shoulders *g*, and the shaping-knife I, adjustably secured on said carrier by the bolt *f*, in combination with the adjustable sleeves G and H, held rigidly together by the shouldered bolts *a* and to the sliding standard D by the V-shaped ring *e*, formed on the sleeve H, and having guides for the carrier-arms *k* and *l*, and said carrier-arms, substantially as described, and for the purpose specified.

4. The standard C, the sliding standard D, the hollow shaft A supported by said standards, and the drum F, cast solid with said shaft and adapted to carry the shaping-knives, in combination with the shaping-knives, and the sleeves G and H, held together by the shouldered bolts *a* and to the sliding standard D by the V-shaped ring *e*, formed on the sleeve H, substantially as and for the purpose specified.

5. The shaping-knives, sliding standard, sleeves G and H, cam or pattern wheel R, counter-shaft S, rod O, bell-crank Q, and the drum F, adapted to carry the shaping-knives I and situated between the sleeves G and H, held to the sliding standard D by the annular projection *e*, formed at one end of the sleeve H, in combination with the lever K, pivoted at K' and adjustably connected to the cam or pattern wheel R by the rod O, and bell-crank Q, having the roller *t*, adapted to revolve in the groove *u* by the motion of the eccentric pattern-wheel R on the counter-shaft S, substantially as and for the purpose specified.

6. The sliding standard D, bell-crank Q, pattern-wheel R, having groove *u*, trunnion M, thumb-screw N, and lever K, pivoted at K' and having its upper end connected to the sliding standard D at *p*, in combination with the rod O, actuated by the bell-crank Q, the free end of which is adapted to move in the groove *u* in the pattern-wheel R, and having its threaded end fitted into the thumb-screw N, which thumb-screw is screwed into the trunnion M, pivoted at *q* on the lever K, substantially as and for the purpose specified.

7. The counter-shaft S, bell-crank Q, having slot W', lever K, bolt P, sliding standard D, and the rod O, at one end adjustably connected to the pivoted lever K, which actuates the sliding standard D, and pivoted at *r* to the bolt P, which is adjustably held in the slot W', formed in the bell-crank Q, having roller *t*, pivoted at its free end, in combination with the pattern-wheel R, driven by counter-shaft S, and having groove *u* formed therein, substantially as described and specified.

8. The shaft A, standard C, and the steady-

ing-pipe U, fitted into the discharging end of the shaft A and rigidly secured to the standard C, having slot *w* formed in said pipe, in combination with the spring *v* and rings X and Y, substantially as and for the purpose specified.

St. Catharines, July 13, 1887.

WM. CHAPLIN.

In presence of—

J. D. CHAPLIN,

JNO. C. NOTMAN.